

6.0 INSTALLATION PROCEDURES

INTRODUCTION

The purpose of this section of the manual is to give a detailed description of proper installation methods of NUDURA's Integrated Building Technology. It is also intended to make sure all the necessary steps are taken to ensure a successful build occurs.

As outlined in Chapter 4, site preparation will play a key role in ensuring the following installation procedures are completed most efficiently and that the project is successful. This chapter is laid out similarly to how a typical building is constructed; starting at the footings and ending with the exterior finishes that can be applied to NUDURA's Integrated Building Technology.

6.1 FOOTINGS

Footings are designed to transfer and distribute the loads applied from the building structure without exceeding the safe load bearing capacity of the soil or rock on which they bear. **IMPORTANT!** The footing should be placed on undisturbed native soil or a compacted granular base as per local code requirements.

When developing footing and foundation plans, always remember that the concrete face is located 2 5/8" (67 mm) inboard of the outside face of the form to which the finish will be applied. This also means that edge projections of footings (often used to determine footing thickness) must take into consideration that on either side of the wall the insulation element positions the face of the insulation this same distance beyond the concrete structure on either side of the wall. The projection distance is calculated from the concrete, not the insulation face.



FIGURE 6.02

If a design is specifying brick or stone veneer above grade to be carried on a brick ledge form, always remember that the NUDURA® system CANTILEVERS the brick veneer BEYOND the face of the insulation of forms extending to the footing by an exact distance of 4 1/4-inches (108 mm). Therefore, the footing plan must correspondingly reflect this difference. **NOTE:** If Taper Top forms are used in conjunction with forms that are 4-inches (102 mm) narrower in cavity width than the form below, this allowance would NOT be required for the design.

Always check the layout prior to placing tools and material in the work area. At most construction sites, it's usually more efficient to work from inside the perimeter walls. All materials and tools required for the assembly of the wall should be placed inside the footing area or on the slab.



FIGURE 6.04

Special care should be taken to have form units accessible where needed while maintaining a 7' (2.13m) clear distance around the perimeter of the walls to allow room for the alignment system installation discussed later in this chapter. Also a clean, accessible work site will prove to be beneficial both in terms of production and safety.

INSTALLATION PROCEDURES

Considerations for footing design for walls formed with NUDURA® Integrated Building Technology Forms are (for the most part) no different than footings for standard poured foundation walls or concrete masonry walls. The same parameters of soil type, bearing capacity, building type, occupancy type, overall building height, floor material types, exterior finish, water table, and seismic classification obviously apply as equally to the design of NUDURA® footings as they do in traditional foundation materials design.

However, the contractor should remember that the unique elements that NUDURA® brings to a building site mean that there are a select number of things to consider during the structural design phase (i.e. the wall form product is composed of EPS foam, and remains part of the finished structure and that EPS foam can be readily shaped to suit site conditions when required).

Finally, vertical reinforcement dowels provide lateral support at the base of the wall. The dowels must be placed in the footing or slab edge at the center of the monolithic concrete wall. The dowels serve as a construction joint reinforcing connection and vertical wall steel does not need to be tied to these dowels. Please refer to the local building code for the area of the project to reference the on-center spacing and diameter of bar needed for this connection.



FIGURE 6.05

FOOTING TYPES (STRIP, SOG, GRADE BEAMS AND PILES, SOLID BEDROCK)

NUDURA® Integrated Building Technology can be modified to create reinforced structural walls that can rest on basic strip footings, slab on grade (SOG), and grade beams connected to piles. The forms can also be scribed to bedrock.

When strip footings or slabs on grade will be used, NUDURA® recommends that they be installed to within $\pm \frac{1}{4}$ " (6mm) of level. This tight tolerance in footing or slab level is one of the fundamental keys for a quality NUDURA build. Unlike conventional forming, NUDURA® forms will need to be leveled following the 2nd course of form placement. By forcing the footings or slabs to be poured within the above noted tolerance, the 2nd course leveling operation can proceed efficiently with minimal need for shimming or cutting the foam to bring the form system to proper level.



FIGURE 6.06

Grade Beams can be created using NUDURA® Integrated Building Technology that can span across, and connect onto, piles driven into the ground. In these situations, an engineer's design is required to ensure the grade beam is reinforced to support the loads being forced upon them.

With NUDURA® Integrated Building Technology, wherever a site may dictate, such as sites with steep sloping bedrock, the contractor does not need to form concrete footings to create horizontal surfaces for erection of NUDURA® forms. Instead, dowels can be spiked into holes drilled into the rock (grouted as may be required) in line with the required plan profile. Then, the base of the forms can be simply "SCRIBED" and cut to the rock profile to enable seating of the form into its required position directly on top of the bedrock – a feat that is virtually IMPOSSIBLE with standard forms or concrete block. Sites like these that are normally impossible for access and convenience are easily handled using NUDURA®.



FIGURE 6.08

STEP FOOTINGS

If the design will involve step footings, always remember that NUDURA® forms are 18 inches (457 mm) in height. Therefore, to avoid unwanted waste in cutting the forms on site, installation works best if the step increments are planned in 18 inch (457 mm) step increments where local codes permit. This ensures that even when the forms are stacked with the lower interlock contacting the footing, the form unit extending over the step will stack smoothly and lock into position without the need of cutting off the interlocks. (NOTE: In Canada, for Ontario's requirement for maximum 16 inch (406 mm) high step footings in granular soils, NUDURA® can provide, upon request, engineering documentation that addresses this specific issue.)

The "shoulder", or finished locked surface, of the top or bottom of ALL of NUDURA's forms is actually located ½" (12.7 mm) above the BASE of the form when it is set on top of a footing. This gap represents the depth of each interlock tooth's projection downward below the form shoulder which is ALSO on the top of the unit ready to interlock with the course above it. As stated above, the installers will NOT cut these interlock projections off since there is no need to, as liquid concrete at a slump of 5 to 6 inches (125 to 152 mm) cannot succeed in flowing between the interlocks since the spaces are too small.

INSTALLATION PROCEDURES

If stack height planning requires starting coursing with a half height or partial height form unit, the initial step footing height **MUST** take into consideration the fact that once the form unit is cut and reversed around to interlock with the form unit above it the interlock is no longer present as part of the unit height. To ensure that the first course form shoulder occurs properly in line with the bottom shoulder of the second course, simply pre-plan that the first partial height step footing is exactly $\frac{1}{2}$ " (12.7mm) lower than the partial form cut height measured from the cut to the shoulder (or meeting surface) of the form. See Figure 6.09 for illustration of this concept.

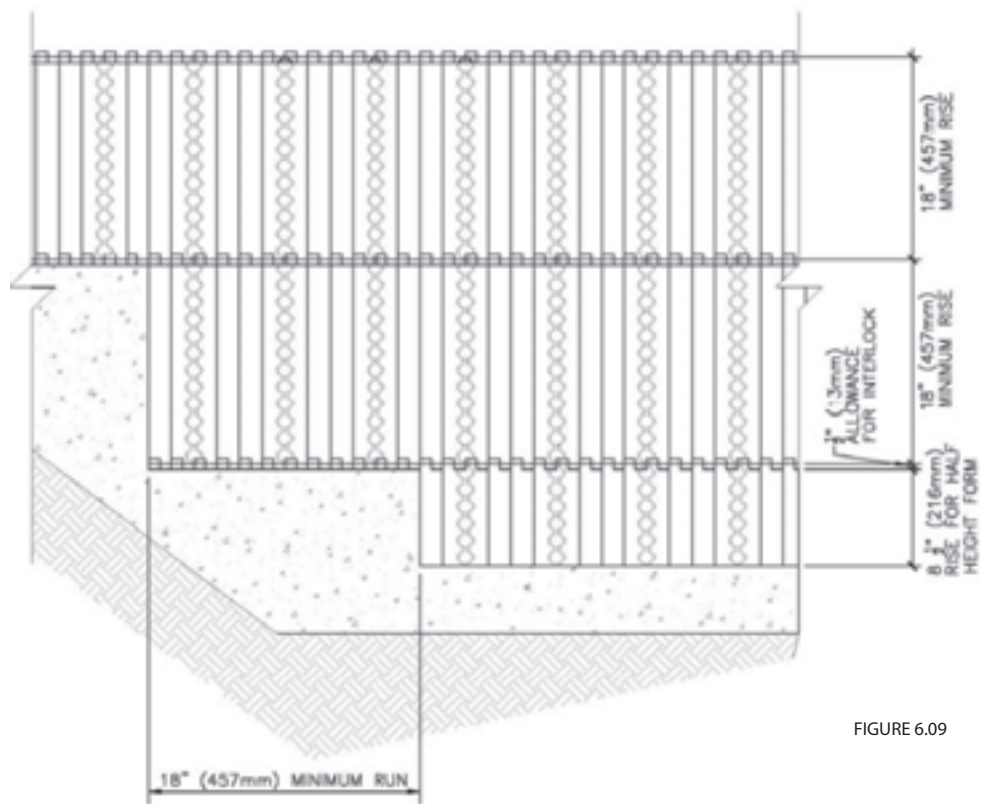

FIGURE 6.09

6.2 FIRST COURSE PLACEMENT

The footing or slab area, where the form units are to be installed, should be free of dirt and debris. Special care should be taken during the installation of the form units to keep the wall cavity free of foreign material. (This includes foam fray that will result from cutting the forms). Extra time spent to establish an effective layout/pattern for the form units in the first course will save time on all the successive courses. This can prove to be a good investment of time, as it will save unnecessary cutting of form units and significantly reduce the need for form support.

NUDURA recommends starting layout on the longest wall at each corner and working towards the center. Establish a pattern around the perimeter of the building. This practice will result in any cut being close to the center of the wall. It will ensure the webs will always be lined up and locked together making it easier for the trades that will follow to attach other building materials to the fastening strips. Additionally, as stated in the introduction section, having the webs line up will virtually eliminate compression during concrete pour.



FIGURE 6.10

Ensure the form units are tight end-to-end to maintain proper dimensions. The vertical joint clips will help ensure the corner and standard forms stay tight end to end. NUDURA® recommends that for the first course 8 vertical joint clips are used for both the corner and standard forms. If cuts are necessary to complete a wall length, NUDURA® recommends, where possible, the form unit be cut on one of the cut lines indented in the EPS (expanded polystyrene). The cut lines must be respected to ensure the foam interlock will continue to lock with the next course of form units. When a contractor/installer cuts on the indented lines it will result in the overall building wall dimensions, having a maximum length tolerance of $\pm 1"$ (25mm).

Important Note: If the contractor/installer needs to cut a form with more than 4" (102mm) of EPS extending beyond the last web, additional form support will be necessary to ensure that during concrete placement these areas do not create a problem under pressure. One method is to use the 1" (25mm) fiber tape to tape from one panel through to the other panel as shown in Figure 6.11. Care must be taken to ensure the forms are dry and free from moisture as the tape will not adhere to the foam in these conditions.



FIGURE 6.11

Alternatively, strapping can also be used to prevent bulging or problems of the EPS under concrete pressure. Simply take a short length of strapping (long enough to extend past the fastening strip on both sides of the area to be reinforced, approximately 2" (51mm)) and screw into the fastening strips. Typically 2 straps per form height will be required to give sufficient form support. This method must be performed to both sides of the form.

Special attention must be given to ensure that the building corners are square when making an adjustment to any wall dimensions. In plan layouts where dimensions are critical to local setback requirements, or specific required interior room dimensions, an "off-cut line" (vertical joint) seam is an alternate method of layout. It should be located near the center of the wall length. So long as the off-cut line seam occurs at the same point on all succeeding courses, and is supported with wood strapping or fiber tape at each course, there is no concern posed by the vertical stack joint created since the form fastening strips structurally link with each other. NUDURA experienced installers have found that cutting a 3' (914mm) long piece of form lock and installing it into each course helps to keep the joint in line.



FIGURE 6.12

INSTALLATION PROCEDURES

Ideally, by following these rules, there should be no need to cut any corner forms and the 16" (406mm) off-set stacking pattern that's established by reverse stacking one corner form over top another will be maintained.

Invariably, however, there will be some plan layouts where wall lengths between corners are so small that either off-cut lines or cutting the corner forms (along with "soldier stacking" of these components) will be necessary in order to complete construction of the wall. In these cases, additional form support will be required.

SPECIALTY ELEMENTS TO BE CONSIDERED AT FIRST COURSE PLACEMENT

NUDURA® T WALLS

During first course placement, NUDURA's T Wall forms need to be considered in the same context that a corner form would be. Layout options should be similar to those discussed above, by starting at the corners on long walls, working towards the center and planning for insertion of a vertical stack joint where needed. Again, contractors should ensure they maintain a 16" (406 mm) vertical joint offset to best guarantee that the forms resist concrete pressure in this area. Typical areas in which a T Wall intersection might occur are unheated storage rooms, foundation wall to attached garage walls, and sunroom foundations. Additional bracing will be required to resist the increased concrete fluid pressures in this area.

NUDURA® also recommends bracing the T Wall forms internally by using the following method; Place horizontal reinforcement within the main wall, extending one or two webs past each side of the T connection (See "Position A," Figure 6.13) then cut two pieces of reinforcing steel 1" (25mm) longer than the cavity width, inserting at either the first or second web (See "Position B," Figure 6.13) in the T connection and tie to the reinforcing steel in the main wall.

Repeat this process at each successive course, but remember not to over tighten the tie wire as it might create an indentation in the main wall. The contractor/installer will not have an opportunity to release the wire embedded in the concrete once concrete has been placed within the wall cavity.

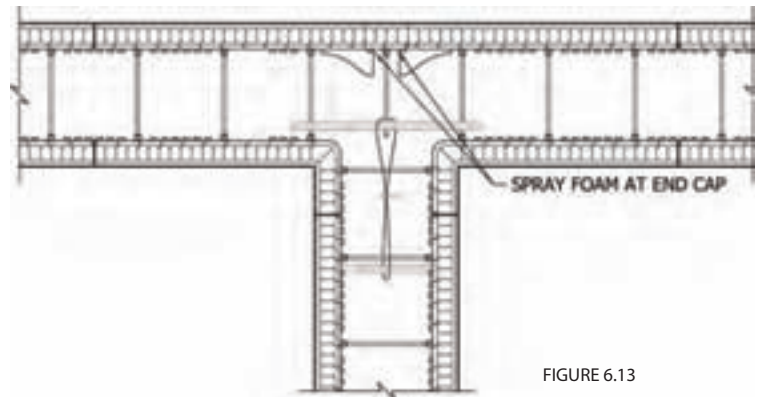

FIGURE 6.13

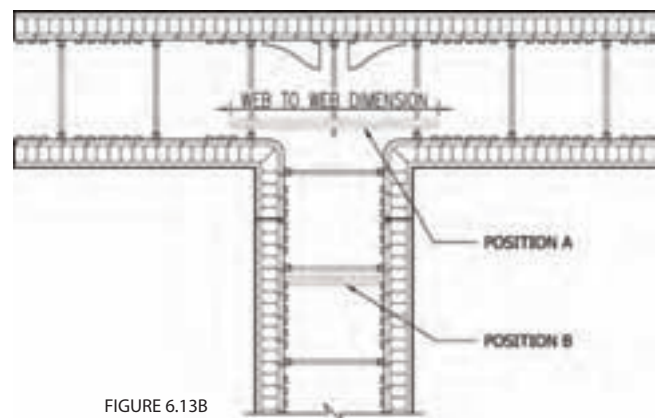

FIGURE 6.13B

VERTICAL STACK JOINTS

Sometimes, (particularly for smaller site conditions) a plan design may dictate the need to cut the forms off the guide lines provided on the forms in order to force the final building layout to precisely conform to the floor plan. In this case, a "Vertical Stack Joint" is necessary. A vertical stack joint is completed simply by butting the forms against one another at the vertical seam up the height of the wall. Additional bracing, either internally or externally, will be required to resist concrete pressure in this area. As discussed previously, the installation of a piece of form lock ensures the wall

maintains straightness, but additional bracing can also be used to prevent separation of the forms during the concrete pour. Additional internal bracing can be as simple as taking a length of tie wire and wrapping it around the closest webs to the vertical joint, then connecting the wire to it. This procedure needs to occur at both the top and the bottom web of the form and is repeated for every course within the wall height to be constructed. Remember to not over tighten the tie wire as it can put undue pressure on the webs and creates problems during concrete placement. External bracing can be done very simply by taking scrap pieces of footing (footer) wood stakes or spreaders and screwing these to the fastening strips on either side of the vertical joint. Ultimately these pieces will need to be no longer than 16" (400mm) and a minimum of two pieces per course will be required.

RADIUS WALLS

The same consideration for T Walls needs to be given during planning and first course placement for radius walls. The important thing at this stage of construction is to mark where the radius will start and end in its connection with the straight walls that form part of the first course. Identify from the plan, the focus of the radius and chalk it accurately onto the slab or footing, by carefully triangulating its location from adjacent straight walls and/or references from the floor plan. Next, using the radius focus, chalk the outside and inside line radii of the wall onto the strip footing or slab to the start and end point connections with the straight walls of the plan. Since these connections will typically be butt or mitered joints and will require a vertical stack joint of some type, the radius wall can be constructed independently of the rest of the build. For more details on radius walls estimating, assembly and construction, refer to the Technical Bulletin on Radius Wall Construction included in Appendix F of this manual.



FIGURE 6.15

REINFORCING STEEL PLACEMENT

Steel reinforcement shall be installed as per the plans and specifications prepared by a qualified designer. The placement of the reinforcement steel shall conform to local standards, regulations or codes having jurisdiction.

Horizontal reinforcing steel should be installed into the notches (sometimes referred to as capture lugs or cradles) provided in the web, allowing for easy and secure placement. Unless specified otherwise by the designer, horizontal reinforcement is always installed after each course of form units is placed. NUDURA recommends alternating the position of the horizontal reinforcing steel from one successive course to another. This practice creates a cage that maintains the alignment of the vertical reinforcing steel which will be installed later. (See Section 6.8)

Reinforcing steel is typically placed on the tension side of the wall below grade and in the center of the wall for above grade applications. Typically, the steel arrives to the site in lengths of 20 feet (6 meters), which means that for almost all projects it will need to be spliced together to act as a continuous length of reinforcing steel in a wall. Except for a 4 inch (102mm)



FIGURE 6.16

INSTALLATION PROCEDURES

core wall, lap splices are typically installed using “non-contact” lap splices as are provided for under most nationally adopted concrete codes. Lap splice length is typically calculated using the formula of 40D (40 multiplied by the diameter of wall steel specified). See Note 1.

For example, let’s suppose a wall needs #4 (10M (actual size 11.3mm diameter)) horizontal reinforcing steel. The contractor or installer simply needs to calculate the lap length by multiplying $40 \times \frac{1}{2}'' = 20''$ ($40 \times 11.3\text{mm} = 450\text{mm}$). Therefore, each horizontal reinforcing steel should overlap one another by 20” (450mm). (Note the conversion factors for metric are different because of the differences in steel diameters given).

There are two types of lap splices: Contact lap splices (which means the reinforcing steel is touching and needs to be tied), and non-contact lap splices (which means the reinforcing steel can be separated up to 1/5th of the lap length to a maximum of 6” (150mm) and does not need to be tied). Using the example above, the separation of the 2 pieces of reinforcing steel would be calculated using the formula 1/5th of the lap length. See Note 2

Therefore, $1/5 \times 20'' = 4''$ ($1/5 \times 450 = 90\text{mm}$). The maximum separation for a #4 (10M) piece of reinforcing steel will be 4” (90mm). The reinforcing steel does not need to be tied if proper alignment is maintained by the notches in the webs prior and during the placement of concrete. The table below calculates typical reinforcing steel sizes and the maximum separation of these sizes;

Standard Imperial Reinforcement Lap Splices			
Reinforcement Size (Diameter)	#4 (1/2")	#5 (5/8")	#6 (3/4")
Lap Length=40 x Reinforcing Diameter	20"	25"	30"
Maximum Separation=1/5 x Lap Length	4"	5"	6"
NOTE: Maximum Reinforcing Separation is 6"			
Metric Reinforcement Lap Splices			
Reinforcement Size (Diameter)	10 mm (Actual Size 11.3mm)	17 mm (Actual Size 16mm)	20 mm (Actual Size 19.3mm)
Lap Length=40 x Reinforcing Diameter	450 mm or 18" lap	650 mm or 26" lap	750 mm or 30" lap
Maximum Separation=1/5 x Lap Length	90 mm or 3 1/2"	130 mm or 5 1/2"	150 mm or 6"
NOTE: Maximum Reinforcing Separation is 150mm			

Note 1: Reference: ACI-318-08 Section 7.6.6.4 / CAN/CSA A23.3-04 Section 7.4.2.3

Note 2: Reference: ACI-318 Section 12.14.2.3 / CAN/CSA A23.3-04 Section 12.14.2.3

6.3 SECOND COURSE PLACEMENT AND LEVELLING

NUDURA® recommends that the contractor/installer start the second course at the same corner as the first course, following the same steps of working from each corner towards the center of the wall. When placing the second course corner forms, each corner form unit will be reversed to create an automatic 16" (406mm) offset or "bond" stack with the form units on the first course. Again, remember to align the units in place and press the form unit firmly downward until the web interlocks "snap-lock" together. After the form unit is in place, as mentioned in Chapter 3 (Tools), a rubber mallet can be used to ensure that the interlocks are properly seated tightly together.

Additionally, NUDURA® recommends that in the corners, 4 vertical joint clips are snapped into place locking the corner to the adjacent standard form. Although, as stated earlier, 16 inches (406mm) is the ideal offset (as established by the corner forms), a minimum of 8" (203mm) staggering of vertical joints should be maintained between courses to ensure that the interlock mechanisms on the end of each web will secure the forms tightly together. Should a vertical joint be less than 8" (203mm), the contractor/installer will need to add additional form support. This can consist of sheathing or 1" x 4" (19mm x 89mm) lumber attached to the fastening strips using #10 x 2" (51mm) wood screws.

Once the second course of forms has been locked into the first course, the horizontal reinforcing steel will, once again, need to be placed within the webs. Remember to offset the bar location by 1 notch (from the corresponding bar in the course below) to ensure the vertical steel can be easily woven between the horizontal steel bars. Additional to the reinforcing steel being placed within the forms, NUDURA® strongly recommends that a row of form lock now be placed within the cavity of the wall to maintain straightness. Refer to Chapter 5 for installation instructions of the form lock.

Once the second course has been completed, the forms will need to be leveled to account for any uneven areas of the footings or slab. Although the footing/slab can be checked prior to installation of form units, the best method is to correct any deficiencies after the first 2 courses of NUDURA® form units are installed.

The forms will bridge over low areas of the footing and ride on the high points. A laser or builder's level can be used to easily set elevations, ensuring the walls finish at the desired elevations. It is easier to fill in hollow or low areas under the form than to cut the form where footings are high. Usually, the fix for uneven footings will require both shimming and cutting.

Upon completion of leveling the forms, the contractor/installer can either foam the forms to the footing (footer) or slab or install form/guide boards. NUDURA® recommends using the low expansion spray foam as the method of securing the forms to the footing (footer). This will not delay the contractor/installer from continuing with additional form placement for the project, as the spray foam sets within 15 minutes of placement. Also, upon completion of pouring concrete in the forms, no additional time will be required to remove this material before backfilling occurs. NUDURA's low expansion spray foam will be completely cured after 24 hours.

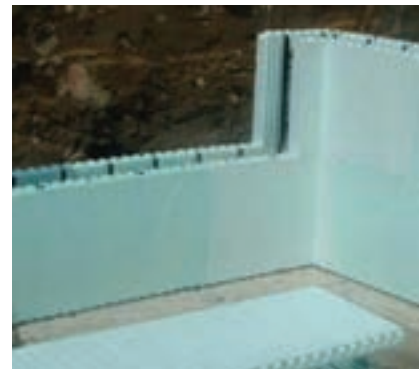

FIGURE 6.17



FIGURE 6.18

6.4 ADDITIONAL COURSE PLACEMENT

As discussed in Sections 6.2 & 6.3, the layout of the first 2 courses of form units are extremely critical as these set the benchmark for all additional courses above. The contractor/installer can now simply follow the pattern established within the first 2 completed courses of forms. For example, the first, third, and fifth courses, or all odd numbered courses, should be stacked identically. This includes all form cuts, rebar placement and splice laps. The same placement method is followed for the second, fourth and sixth courses, or all even numbered courses. If vertical stack joints are present within the wall length, these will need to be maintained up the entire height of the wall. The only areas that will need some modifications are around the openings and possibly service penetrations. These will be discussed in Sections 6.5 & 6.7.

Additional form support may be required to prevent movement of the forms during concrete placement as covered in Section 6.2. The following conditions may also require additional support:

- If there is more than 4" (102mm) extending beyond the web at a cut end
- Minimum 8" (203mm) vertical offset is not achieved, or cut is next to a corner
- T-walls on the main wall side to resist concrete pressure
- Tapered Top form needs additional reinforcing on the top edge of the tapered side
- Window or door openings near a corner

All of these situations will need additional form support to ensure movement does not occur during concrete placement. Again, fiber tape, strapping, or strips of sheathing will work in these difficult areas.

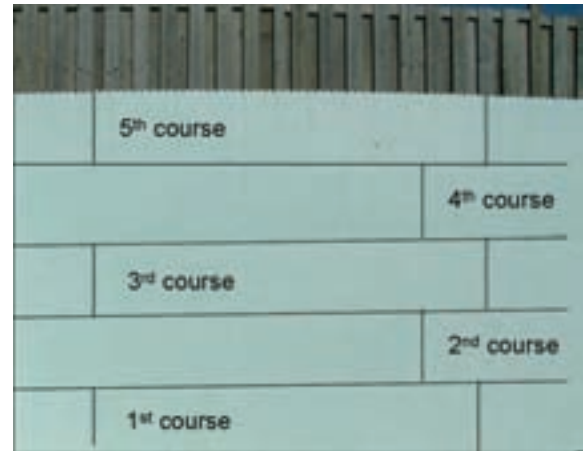

FIGURE 6.19

6.5 OPENINGS

Window and door openings can be easily created within NUDURA's forms using a number of different buck materials to frame and hold back the fluid concrete until curing has occurred. These methods can include lumber material (pressure treated or wrapped plain lumber), EPS end caps with lumber material for the header, vinyl bucks, steel bucks, or with the NUDURA® Easy Buck (a composite buck system using lumber inserts).

The Rough Opening (RO) dimension is the opening required to install the window or door, allowing for adjustment and additional insulation at the time of installation. It is important to establish if the type of buck being used is "stay-in-place" or to be removed prior to the installation of the window or door.

The RO in a "stay-in-place" buck will be the interior dimension of the buck. Remember to allow for the thickness of the buck material being used.

Wood bucks can be constructed using 1" (19mm) or 2" (38mm) dimensional lumber which is the same width as the overall wall thickness. (Including EPS insulation)



FIGURE 6.20

Wood bucks can also be created by inserting cut or widened lumber in the cavity of the form to create the required opening. It can be secured in place with expanding foam sealant and temporarily cross braced until concrete has cured.

The buck can also be built using the Easy Buck material as a “stay-in-place” buck. The method consists of a combination of the Easy Buck and dimensional lumber. When anchoring the Easy Buck to the wood, NUDURA® recommends the contractor/installer use #10 (metric version) 4”-5” long screws, and screw through the Easy Buck into the wood, extending the screw to the inside of the form cavity. By extending the screw through the wood material and having it exposed to the cavity area of the form, once concrete is cast into the wall it acts as an anchor point for the buck material to be connected to the concrete wall. This ensures that the buck material will not move once the windows/doors are installed.

Another method is to create wood bucks that are 2 5/8” (67mm) smaller than the overall form depth and utilize the NUDURA® Easy Buck on one side of the wall. This allows interior finishes to be fastened directly to the wood material, but also creates a thermal break through the forms. One caution to using the Easy Buck system for the outside, is that should the exterior finish be specified as a stucco material, the Easy Buck must be removed (by cutting the outer plastic capture fins away) to allow proper bonding of the stucco to the EPS.

Bucks can also be created using NUDURA® end caps with fastening strips. The head of the buck is usually created with lumber in a similar fashion as for the wood buck. If greater depth is required for the concrete lintel, the buck should be constructed to allow for the removal of the lumber used in the head of the buck. This will result in a concrete lintel 1 1/2” (38mm) deeper.

When constructing the bucks that will be used for the openings, the sill areas need to be left open to allow for concrete placement. One option would be to use 2” x 2” (38mm x 38mm) or 2” x 4” (38mm x 89mm) lumber for the sill of a window buck. This allows access for the contractor/installer to completely fill the area below the window with concrete and also screed it smooth. Another option would be to use a solid piece of buck material and cut access holes to ensure concrete completely fills these areas. Whether the buck material stays in place or is removed will be a decision for the contractor/installer, but having access to this area will allow different finishing options to be used. Concrete



FIGURE 6.22



FIGURE 6.24

INSTALLATION PROCEDURES

finishing options include finishing the concrete flush with the top of the buck material, or finishing the concrete flush with the top of the forms and remove the buck material used for the sill area of the opening. Pressure treated lumber may be required in certain applications as per local code requirements, and should be wrapped on the back side of the lumber material with a minimum of 6 mil poly to ensure the wood does not come into contact with the concrete. When the buck material is designed to stay in place and the window or door is to be fastened to it, it is important to provide proper anchorage of the buck to the concrete as per code requirement.

Prior to the concrete placement, all required means of form support must be installed to resist fluid concrete pressures. Any corners of 8' (2.44 meters) or less from an opening will require form support, tying the corner back to the buck. Alternately, exterior bracing could be installed to provide support to the corner forms.

LINTEL REINFORCEMENT

As covered already in Section 2, lintel reinforcement requirements will vary based on the loading conditions, depth of lintel, width of opening, concrete strength, and wall thickness. NUDURA® Corporation has prepared Engineered Lintel Tables for NUDURA® walls that can be used for submission to the building department as well as in the building process in field. These lintel tables are designed for a concrete strength of 3000 psi (20 MPa) and are included within this manual under Appendix E.

If your project drawings have been produced using NUDURA's Installation Manual as outlined under Section 2, then you can proceed straight to installation of the required lintel steel per either the specifications on your drawings or on the lintel schedule that would be attached to the drawings. If not, please refer to Section 2 for details on how to use the lintel tables and to calculate the required uniformly distributed loads for the project.

Refer to Figure 6.27 which is a diagram of a typical opening that shows the different reinforcing pieces and where they must be placed in order to correctly install lintel steel. This diagram has been taken from the page preceding the lintel tables in Appendix E and shows the key items that must be completed to ensure proper placement of the reinforcing steel has occurred. This also allows the contractor/installer to understand what key items need to be extracted from the tables for construction of the lintel.

Additional to the lintel steel, you'll also see that the diagram requires 2- #4 (10M) bars to be placed vertically on either side of the opening and 2- #4 (10M) bars placed horizontally at the sill location of the opening extending 24" (610 mm) into the solid wall.

TOP STEEL PLACEMENT

If using the lintel tables within this manual, the top reinforcing steel will always be 1- #4 (10M). This piece of steel will extend 24" (610mm) past each side of the opening into the solid wall and be placed in the center of the wall cavity. The contractor/installer must ensure that during concrete placement the pour needs to terminate 1 ½" (38mm) above the top reinforcing steel.

The top steel can be installed in one of 2 ways.

- (a) Clip the top steel in position on the reinforcement steel notches on the top of the form webs that are located at, or very near, the required top steel position within the lintel height. This would be automatic if your coursing height works out to be in line with the designated finished top limit (including concrete cover) of the lintelor...
- (b) Hang the steel at the exact required position using 3 (or more) tie wires to suspend it at the correct height within the lintel area from the closest horizontal reinforcement bar above it. This will likely be required if the course heights in the wall do NOT line-up with the designated top of the lintel

INSTALLATION PROCEDURES

BOTTOM STEEL PREPS

The bottom reinforcing steel will be determined through the tables based upon loads, opening width, and depth of concrete. It too must remain in the center of the wall cavity and extend 24" (610 mm) into the solid wall on BOTH SIDES of the opening. Again, the bottom reinforcing steel must be encased with a minimum/maximum 1 ½" (38mm) of concrete coverage.

As per specification from the tables or lintel schedule, if the bottom steel is a single bar, cut it to the required length and set the bar in position on top of the window buck, which the lintel will be supporting over. If the bar is to be bundled, tie wire the bars together with 2 or more ties to ensure they react as a single unit. If the bottom of the top of the buck will be beyond reach of the top of the form unit in which the lintel is being assembled, position 2 or more lift wires (again using tie wire) under the bar to help assist lifting the bar into position. If NO stirrups will be required, you can use these tie wires to properly suspend the bar at its required height.

SHEAR STIRRUPS AND FINAL BOTTOM STEEL PLACEMENT

Per Section 2 of the manual, the stirrup end distance obtained from the tables (or your drawing lintel schedule) is the distance from the edge of EACH SIDE of the opening to where the first stirrup will be placed near the center of the opening. (Again, refer to Figure 6.27) The stirrup spacing is also determined within the tables and starts from the specified stirrup end distance. The stirrups will then be suspended at regular centers from the top steel bar at the specified spacing requirement, working from the center of the opening towards the solid wall on either side of the opening. Should the distance between the last stirrup and the solid wall be more than ½ of the stirrup spacing required, an additional stirrup will need to be installed. The last stirrup will be placed using the stirrup spacing required and may result in the stirrup being located past the edge of the opening in the solid wall. For example, if the stirrup spacing was 10" (254mm) and the distance to the solid wall was 6" (152mm) (more than half of the spacing) then an additional stirrup is required. In this example, the final stirrup will be located 4" (102mm) into the solid wall past the edge of the opening.

Once the shear stirrups are in place, the final step will be to hoist the bottom steel bar, single or bundled, into finished position to properly cradle the steel into the bottom curls of the shear stirrups. On longer lintels, 2 workers may be required to pull the bar into position.

SPECIAL CONDITIONS AT OPENINGS

This section discusses special issues that may arise with respect to wall openings including:

- Radius Topped Windows or Entrance Frames
- Bow or Bay Window Conditions
- Corner Windows

Radius Topped Openings: Radius topped windows or entrance frames can be easily accommodated with NUDURA using one of several options for assembly. The only substantial difference from standard windows is that the lintel steel spans the full opening (regardless of the radius width), treating the very top of the radius portion of the opening as the BOTTOM of the lintel itself.

One option is to construct the opening bucks with curved plywood inserts to suit the required framing opening and shim clearance. The wall area over the opening is then assembled using NUDURA panels and insert webs that are cut and assembled to suit the curve of the plywood buck materials and inserts. As with traditional openings, the radius plywood inserts will require temporary support to be installed below, within the rectangular portion of the opening.

An alternate method is to build the wall as normal, using standard NUDURA® forms, around the square part of the opening to the start of the curved portion of the radius but at the start of the radius (as with the plywood insert

option) revert to NUDURA panels and insert webs, and assemble them straight across the opening. The opening buck below should be assembled rectangularly, ignoring the curved portion being installed above it.

Next, cut multiple foam sheets, sufficient to suit the wall cavity thickness to the exact radius profile required for the anticipated window or entrance frame and shim clearance. Be sure to use these as a drawing guide to trace the radius outline on the outside foam surface on both sides of the wall. Then glue the foam panels in place in the cavity over the rectangular opening buck.

Cut and assemble the required insert webs over the radius cut foam billet that is filling the cavity. Install the lintel steel as specified above.

Once the concrete is cured and the buck supports are ready for removal, simply follow the guidelines to cut the foam tight to the concrete. The result will be a perfectly curved concrete radius ready to suit the window or entrance frame specified.

A third option is to build the wall as normal with NUDURA panels and insert webs, again ignoring the curved portion of the opening, but constructing the wall above the standard portion as follows:

1. Trace the required radius top over the opening using the desired frame and shim clearance pattern on both the inside and outside of the wall forms installed above the opening.
2. Using a keyhole saw or jig saw, carefully cut the foam panels and web materials on either side of the wall, but retain these materials for immediate re-use. Be sure to examine the cut webs and insert new inserts or height adjuster ties as necessary to reinforce the panels as required where the curved line meets the opening. Repeat this for the web materials that link the panel areas that were cut.
3. Next, using aluminum sheet cut to the overall form depth, wrap the complete radius with the sheet material and tape it temporarily in position with fiber tape.
4. Finally, restore the cut portion of NUDURA form work into the position where it was cut out and tape into position, in effect sandwiching the curved metal sheet between the insulation panels along the cut line. Provide buck support below and complete the concrete pour.
5. When the buck supports are removed, simply remove the insulation panel and metal sheet.

Bay Windows, Bow Windows and Openings Near Corners: Questions often arise as to how to handle lintel construction associated with these types of openings. The same methodology applied to straight run window lintel construction should also be applied in these situations, but bending the top and bottom steel to suit the wall's turn in axis. Be sure to adhere to the requirements for extension of both top and bottom steel, even if it means bending the steel around any corner condition occurring near the opening.

A structural engineer may need to be consulted for specifying reinforcement above bay window conditions, even those that are separated by corner mullions. It is likely that the engineer will treat the area as a single opening of width equal to the combined length of the 3 window segments. The lintel steel should be installed accordingly even if there will be steel post supports at the bay window corners.

6.6 NUDURA ALIGNMENT SYSTEM

A key element of NUDURA's product lineup is the NUDURA Wall Alignment System. This system is a multi-purpose set of components aimed at ensuring the forming system has support during concrete placement, while also providing a safe working platform for the contractor/installer. As with any scaffold system, safety must always be monitored on the project. The contractor/installer needs to be aware of, and understand, all safety codes and regulations with respect to spacing, planking, and safety rails. The alignment system has been designed to support the weight of the workers, wind loads, and the weight of the wall only. Should the alignment system be used for things other than what it has been designed for, it may result in failure and possibly bodily harm to the workers using the system.

NUDURA's alignment system has been tested to meet all safety standards for North America, and most European Countries. Should a safety authority request documentation regarding the alignment system and its conformance to the local safety code, this is available through the local distributor for the contractor's/installer's area. Should the use of the alignment system fall outside of the general safety code conformance, site specific engineering will be required.

The alignment system is made up of the following components:

Diagram	Part Name	Part Number	Number of Pieces
A	Turnbuckle (top & Bottom)	tbukl	20 of each
B	Base Plate	bplate	20
C	Catwalk Bracket	catbra	20
D	Guard Rail Post	grail	20
E	3/8" x 2 1/2" Lock Pin (9.5mm x 63.5mm)	lockpin	40
F	5/8" x 3" Bolt & Locking Nut (16mm x 76mm)	boltnut	20
G	1/2" (13mm) Gravity Pin	g-pins	40
H	8' (2.438m) Box Channel	cha8	20
H	10' (3.048m) Box Channel	cha10	20
H	12' (3.658m) Box Channel	cha12	20

* The bracing components are crated and include the following items (brac-l); Turnbuckles (assembled with foot plates), Catwalk Brackets, Guard Rail Posts, Lock Pins, and Gravity Pins. Box Channels are a separate crate.

INSTALLATION PROCEDURES



FIGURE 6.30

In addition to the alignment system components, NUDURA® offers a steel crate that will neatly contain 20 complete sets of the bracing including the box channels.

ALIGNMENT SYSTEM INSTALLATION

1. There are a few things that the contractor/installer should check on the alignment system to ensure it is in good working order before assembling the components onto the wall.
 - (a) Check each component to ensure none of the pieces are bent, cracked, or worn out. Should the contractor/installer notice any pieces that pose any type of safety risk, the pieces need to be removed from the set and excluded from use on the wall
 - (b) Ensure the threads on the turnbuckle move freely for the full length of the threads.
 - (c) Should it become difficult to turn the threads, a light grade lubricant or general purpose grease needs to be applied onto the threads.
2. The NUDURA® alignment system will only need to be placed on the one side of the NUDURA forms, preferably on the inside perimeter of the building. The alignment system will need to be laid out on the wall at 5'- 4" (1.63 m) on center spacing. This will allow for proper plank spacing, as well as sufficient overlap. Remember that when laying out the spacing of the box channels the contractor/installer should also take into consideration the floor joist layout and connection method. The box channel layout may conflict with these embeds and might need to be adjusted. Also, remember to add additional braces on either side of openings. Depending upon the size of the openings, one brace may have to be placed within the center of the opening.
3. Once the layout has been completed, the contractor/installer will need to attach the box channel (closed end (base) at their feet) to the wall. Within the NUDURA® form system, every 8" (203mm) on center there are 1 ½" (38mm) wide fastening strips located 5/8" (16mm) below the surface of the EPS foam. These are marked with a diamond shaped pattern running vertically along the form. Place the box channel up against the form, remembering to line up the outside edge of the channel with the first cut line on either side of the fastening strips. This will ensure that the box channel stays plumb the entire height of the wall.



FIGURE 6.31

INSTALLATION PROCEDURES

4. Next take a #10 cut screw (NUDURA Hex head screw w/steel flat washer SC-2.0), placed close to the top of the slots at the back of the box channels and using a cordless screw gun, drive the screw into the fastening strip (Figure 6.32). Remember to not over tighten the screw as the forms need to be able to slide vertically within the slot on the box channel to allow in the ease of straightening. One screw per slot is necessary up the entire height of the wall. Also, the base of the box channel can now be mechanically fastened to the base it is resting upon.
5. Next, connect the adjustable diagonal pole brace to the box channel using the ½" (13mm) diameter gravity pin, as shown in Figure 6.33, and anchor the diagonal foot pad base to the ground or floor with either drift pins or a #10 cut screw (NUDURA Hex head screw w/steel flat washer SC-2.0).

Contractors/installers are responsible for the holding capabilities of the drift pins/fasteners used to anchor the diagonal foot pad base. Also, remember that different lengths of drift pins will be required based upon soil type.
6. Once the diagonal foot pad base has been securely fastened, connect the catwalk bracket onto the adjustable diagonal pole brace. Take the catwalk bracket and place it, engaging the hook end of the catwalk platform overtop of the adjustable diagonal pole brace and gravity pin connection.
7. Take the second ½" (13mm) gravity pin and install it through the box channel and bottom leg of the catwalk bracket, securing it together. (Figure 6.35)
8. Finally, the guard rail post can be attached to the catwalk bracket. Simply slide the guard rail post into the catwalk bracket stub and secure it together using the ⅜" x 2 ½" (9.5mm x 63.5mm) lock pin (Figure 6.36). Now, add the necessary wood rails and toe kick rails as required, along with the proper scaffold planking, remembering to have the necessary overlap as needed.



FIGURE 6.32



FIGURE 6.33



FIGURE 6.35



FIGURE 6.36

The alignment system must stay attached to the walls until sufficient concrete curing has occurred. Should the contractor/installer elect to remove the alignment system before the concrete has had sufficient curing time, temporary bracing will need to be installed. Alternatively, the contractor/installer may install the floor or roof system to provide lateral support before removing the alignment system.

IMPORTANT! In below grade applications, backfilling should not occur until sufficient concrete cure has been achieved and the sub-floor has been installed to provide lateral support against backfill pressure. Remember that concrete will achieve approximately 40% of its design strength within 3 days, 60% within 7 days, and concrete will achieve its full compressive design strength at 28 days.

Once the alignment system has been removed from the wall, remember to return the adjustable diagonal pole brace threads to the center position (approximately 6" of thread exposed). Also remove any concrete residue from all components of the alignment system before storage or transporting to the next project.

6.7 SERVICE PENETRATIONS

As with all installation procedures, pre-planning of the service penetrations will ensure that when the time comes to install each service, additional labor is not incurred. Most penetrations that are necessary for a building require the contractor/installer to cut out a piece of the EPS and insert the required size of material for that service to run through. It is NUDURA's recommendation to contact the appropriate sub-trade for the proper size and location of the sleeve.

Below is a list of common service penetrations that may include some or all of the following items for a project;

Water supply	Hot water tank vent
Sewer or septic pipes	Exhaust fan vent
Storm sewer line	Range hood vent
Electrical service	Dryer vent
Oil filler and vent	HRV vents
Natural Gas or Propane line	A/C lines
Gas Fireplace exhaust vent	Air Exchanger
Exterior electrical fixtures and receptacles	Furnace exhaust vents
Audio & video service	Hose bibs
Spares	

Installation of service penetrations is a simple procedure; the contractor/installer will need to cut a hole in the EPS using a keyhole or pruning saw for the sleeve as required. When laying out the locations of the sleeves, should a service penetration be located in the middle of a web, it is recommended to move the sleeve to one side or the other to eliminate the need to cut the web, which will weaken the form. Additional form support around the opening will be required, should it be necessary to cut a portion of the web in order to fit a sleeve into the desired location. If the required sleeve size is larger than 16" x 16" (406mm x 406mm), then it will be necessary to add additional reinforcing steel.

Be sure to use the correct size of conduit to suit each service penetration individually. The contractor/installer should make sure the conduit extends through the wall long enough to permit the use of couplers or fittings at each end. This ensures when the sub-trade has to perform their tasks, the EPS foam around the sleeve will not need to be removed to attach the couplers.

For dryer ducts or other more flexible sleeves, consider fitting the cut plugs of EPS inside the sleeve to provide additional support to the concrete during placement. These can be removed later after the concrete is cured as part of the installer's final strip and clean-up.

Wherever possible, coordinate with the general contractor or the various sub trades for determining any specific requirements that each trade may have (i.e. location, or, (as in the case of plumbing fittings, elevation and required slope of the sleeves) prior to installation.

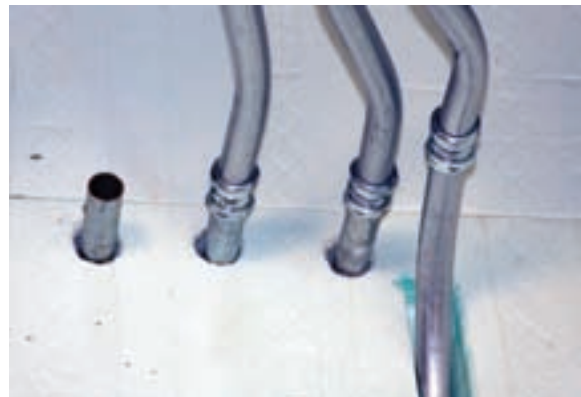

FIGURE 6.37

6.8 VERTICAL REINFORCING STEEL PLACEMENT

Once the desired height of the wall has been reached, and before concrete is placed within the wall cavity, a final row of form lock, as well as the vertical reinforcing steel, should be placed into the wall.

The form lock should be installed first as it needs to be force fitted in between the EPS panels as previously discussed. Once the form lock has been completed, the contractor/installer can now install the specified vertical reinforcing steel. The vertical steel sizes and spacing can be found at the back of this manual in Appendix D. The contractor/installer will need to know if the project falls in a seismic zone, and what the wind loading conditions are for the area. This information can be obtained either by consulting your local applicable building code, or consulting the building department for the municipality where your building project is located.

Alternatively, reinforcing steel can also be determined from the local building code, which again will require the contractor/installer to know what elements the project will fall under for steel sizes and spacing.

Once the vertical steel has been determined, simply start at the corner that has been designated as the starting point for concrete placement and weave the vertical steel between the horizontal steel. This will lock the vertical steel into place and prevent it from moving side to side within the wall cavity. Continue to slide the steel into the cavity at the specified center spacing around the perimeter of the project.

In most of NUDURA's forms, if the vertical steel specified is below No. 5 (15M) in diameter, the horizontal dowels may not fully capture the steel solidly enough to prevent it from moving in the longitudinal direction of the wall axis. In this case, the vertical steel can simply be placed against the webs that are already vertically aligned in the wall. The installer then allows the concrete to push the bar against the web during placement. This will ensure the vertical steel is exactly vertical during placement and that it won't move out of position.

The top of the vertical reinforcing steel will terminate, as specified below, at the top of the forms. Should additional storeys of NUDURA® be needed, wet setting the dowels are recommended over having the vertical steel extend above the last form. An alternative method to wet setting dowels is to install another course of the forms using these forms as a funnel for concrete placement. Remember to terminate the concrete below the top of the forms of the specified lap splice distance as required for the reinforcing steel being used.

After all the form units are installed, and prior to the placement of concrete, the vertical reinforcing steel should be terminated as specified below the top of the wall. If successive storeys are to follow, construction joint reinforcement dowels should be installed as per the vertical reinforcing steel placement.

Field experience has proven it is easier to insert joint reinforcement dowels after the concrete placement versus working with longer, vertical reinforcing steel which can interfere with the concrete placement within the forms.



FIGURE 6.38

6.9 SPECIAL APPLICATIONS

FLOOR CONNECTIONS

Before concrete is placed into the forms, some additional steps need to be considered, dependant upon what stage of construction the project is currently under. If the current stage is the foundation with additional stories to follow, the attachment of a floor will have to now be considered. This is essential because in most residential structures these floors are still wood joists with plywood sheathing. Should the floor connection be something other than light framed wood floors, an engineer's design will be necessary for the reinforcing required in the walls. This method of floor connection does need to be pre-planned before concrete is poured into the forms. First the contractor/installer needs to decide what method will be used for hanging the floor from the concrete wall. There are several methods for connection of the floor joists to the concrete wall that include the following;

- ICF Connector™
- Simpson Strong-Tie (ICFVL™)
- Simple Anchor Bolt
- Modified Anchor Bolt with Moment Connection Plate
- Ledge Support.



FIGURE 6.39

ICF Connector: The ICF Connector System is probably one of the fastest and easiest methods for floor attachment with the least amount of additional labor. A technical Bulletin on detailed installation of this system can be found in Appendix F of this manual.

Simpson Strong Tie ICFVL™: Like the ICF Connector™ System, The Simpson Strong Tie ICFVL™ System connection requires the embedment of a galvanized plate through the foam into the concrete. This will additionally require a ledger board to be attached to the embedment, along with shear connection J Brackets at each embedment, and joist hangers for the floor members to rest into. For the full installation, and recommended spacing, please refer to Simpson Strong-Ties web site.

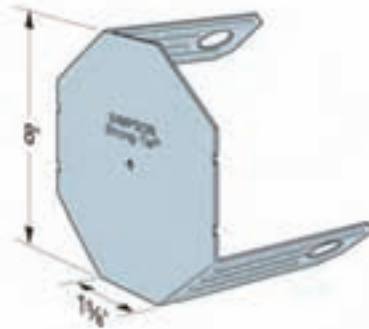

FIGURE 6.40



Simple Anchor Bolt: Although more labor intensive than any other method, one connection method that has the added advantage of being approved under most current prescriptive building codes throughout North America (without the requirement of separate engineering tables) is the use of horizontal embedded anchor bolts. Again, a ledger board and joist hangers are required. This method will require the removal of some EPS foam to allow the concrete to flow out flush with the face of the form. Once the concrete has been placed and partially cured, simply remove the temporary form, drill and attach the ledger board, and connect the joist hangers as required for the floor joist spacing. One thing to note is how the EPS has been cut in the form. These cuts ensure that during concrete placement voids will not occur in this area. Proper consolidation of the concrete will also ensure the pocket becomes encased with concrete. Please refer to proper concrete consolidation techniques in section 6.10.

INSTALLATION PROCEDURES

Modified Anchor Bolt with Moment Connection Plate: Some manufacturers also distribute modified anchor bolts which contain a welded square plate in line with the L shaped bend of the anchor bolt. The plate is designed to the same thickness of the NUDURA EPS panel. These special bolts are engineered to handle the bending moment condition that is typically created because of the extension of bolt beyond the concrete surface. The plate enables transfer of the vertical loads laterally into the face of the concrete. As with simple anchor bolts, this system ALSO requires floor support ledgers and joist hangers. However, the big plus with this system is that the bolts can be pre-installed into the foam with very simple horizontal slit cuts as opposed to having to remove full foam segments making them much less labor intensive to install. Be sure to check with the manufacturer for any supporting engineering documentation for this option.

Ledge Support: A ledge can also be created by using forms of different widths as shown in Figure 6.43. By using NUDURA® Taper Top forms as the ledge for the floor joist to rest on, and connecting a smaller width form to the tapered top (using the NUDURA® Form Transition Bracket Accessory), a ledge is created. The smaller width form must be able to create a ledge that, by code, will allow enough end bearing to support the joist (by most codes 1 ½-inches or 38mm). This method can incorporate the use of bottom chord load bearing floor joist and also top chord load bearing floor joist.



FIGURE 6.43

BEAM POCKETS

Beam pockets are another very important structural element that need to be planned for before any concrete is placed within the forms. Beam pockets can be placed anywhere along the length of a NUDURA® wall. Again, the floor plans will provide the contractor/installer with the exact location of the beam placement to carry the required members to the solid wall. Additional vertical reinforcing steel may be required at these locations to ensure the loads are transferred correctly throughout the wall section. Please refer to Appendix D of this manual for the number and size of reinforcing steel bars required for these areas. If the contractor/installer is referring to alternate design information, check within the appropriate areas pertaining to beam pocket reinforcing. The contractor will need to check all measurements to ensure the pocket is in the correct location to receive the beam at a later part of the construction process.



FIGURE 6.44

One method for creating a pocket is to use 2 of NUDURA's end caps and slide them into the cavity of the wall for the location of the beam (smooth sides facing the concrete). The contractor/installer needs to make sure there is access to screed the bottom of the pocket flat to help reduce the number of shims required for the beam to rest on. The detail on the right demonstrates how the end caps are slid into place along with cutting open an area to allow the contractor/installer an opportunity to screed the bottom of the pocket smooth. Once the concrete has been cast into place and cured, the contractor/installer will simply cut out the EPS and remove it from the pocket area. The beam is then installed similar to typical construction practices.

INSTALLATION PROCEDURES

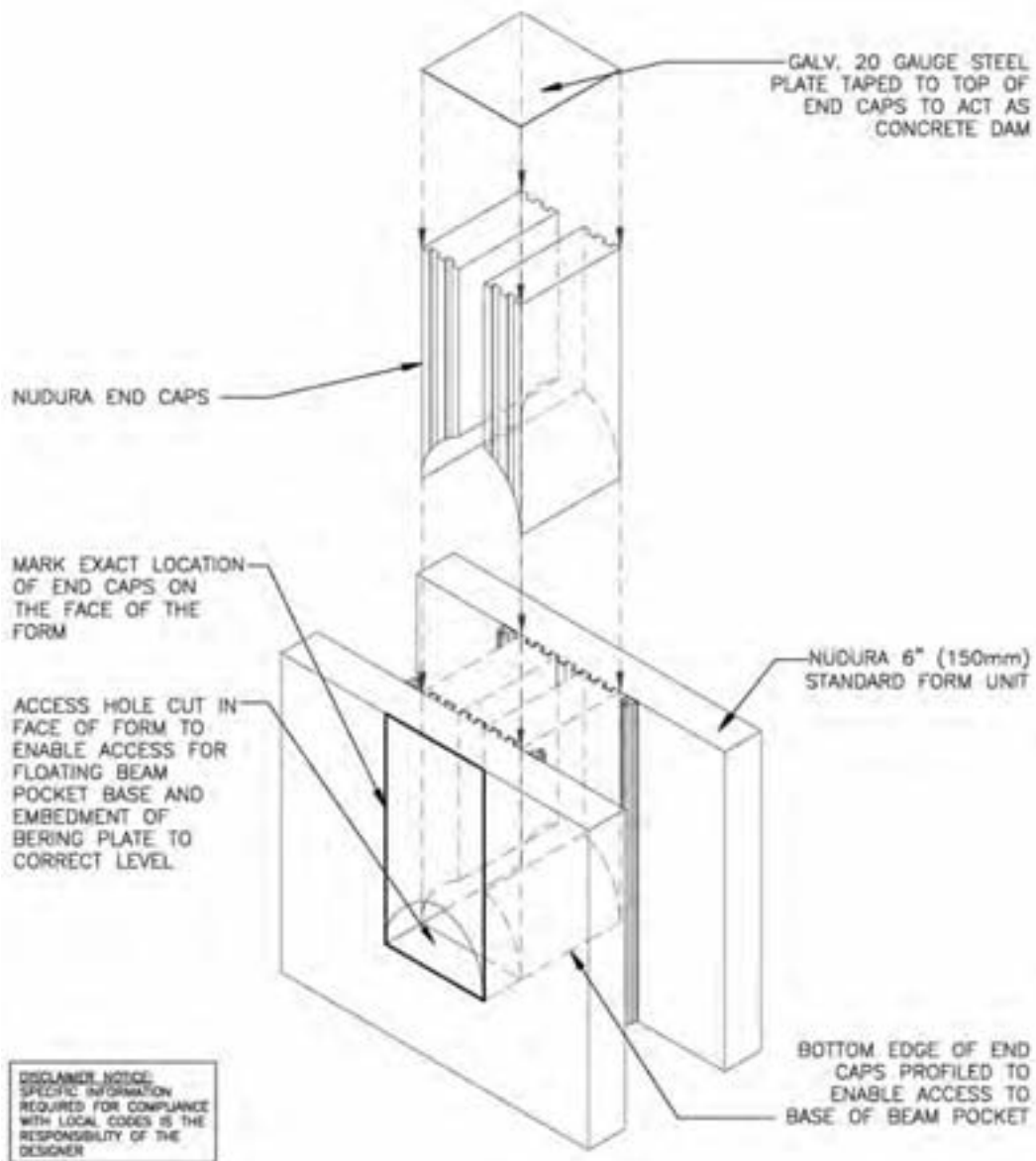

FIGURE 6.45

Another method is to take a piece of EPS foam and cut it to the desired dimensions, then spray foam this to the inside of the panel on the side of the wall that the beam will rest onto. As stated above, access to the bottom of the pocket will allow the contractor/installer the opportunity to screed this area smooth for the beam to rest on later. (Bearing or weld plates can also be taped in place to the bottom of the foam if desired, though care must be taken to adequately vibrate the concrete below the embed plate, using this method). As with the first option, after the concrete has been placed and cured, the contractor/installer simply cuts and removes the EPS foam from the pocket area, and the beam is then installed as per normal procedures.

INSTALLATION PROCEDURES

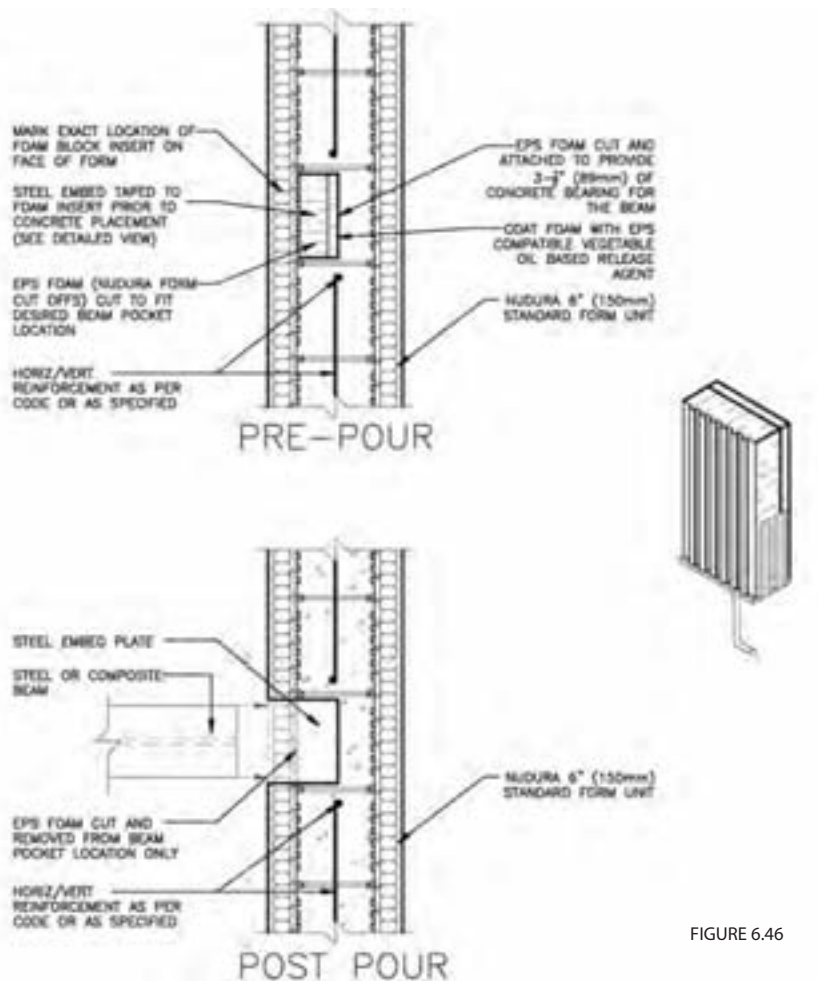

FIGURE 6.46

BRICK LEDGES

NUDURA's brick ledge form units have several uses, including supporting masonry loads and supporting floor joists. However, the brick ledge is not available in a corner form option (in any angle) and therefore the creation of an in-field corner brick ledge will need to be made. Installation of the standard brick ledge follows the same requirements as a standard straight form. Once the contractor/installer comes to a corner condition a decision needs to be made regarding the creation of a corner brick ledge.

Option 1- Full Form Miter Cut: One method for construction of Brick Ledge Corners is to take 2 brick ledge forms and miter cut them following the profile of the corbel on the outside panel, and creating a square cut on the inside panel to complete a corner form condition. Remember that all cuts need to be performed away from the wall area to prevent a build up of EPS shavings (or foam fray) in the bottom of the wall. Once the miters have been completed, take both pieces of brick ledge and lock them onto the wall. NUDURA's 1" (25mm) fiber tape will now be required to tape the corbelled corner and provide strength during concrete placement. Should the miter cuts on the corbel not be exactly tight together, the contractor/installer can fill any gaps using the low expansion spray foam. This will accomplish two things; it will add additional bonding of the two forms at the miter location and it will also fill the gaps, not allowing concrete to leak from this area.

Option 2- Corner Forms with Brick Ledge Extensions: The 2nd method that can be used is to construct the corner using the standard 90 degree or 45 degree corner form as the basic structural integrity of the corner condition, but then, fitting the form with NUDURA's Brick Ledge Extension Form Accessories to complete the ledge condition. This method has the added benefit that it maintains the structural integrity of the standard corner form throughout the condition and can, in most cases, be a more cost effective option for constructing the corners. To see detailed

explanation on the correct method of construction to be used for Corner Brick Ledge Option 2, refer to the Brick Ledge Corner Assembly Technical Bulletin found under Appendix F in this manual.

In either case, once the brick ledge condition has been constructed, the reinforcing steel can now be added to help support the brick that will be installed later in the construction process. The steel needed to accomplish the reinforcing for the brick ledge consists of 3 different pieces. The first is the horizontal steel location in the main cavity of the wall. Its location is critical as it helps to support the brick ledge hooks.

NUDURA recommends that the horizontal steel be placed within the second notch of the web from the inside face of the form.

Also, this reinforcing steel will be required to have a contact lap splice in order for the hooks to be located correctly (see Figure 6.49). At the outer edge of the brick ledge (and the BL extensions), the contractor/installer will also need to place a horizontal piece of reinforcing steel to allow the brick ledge stirrup to rest on. This piece of steel will not require a lap splice as it simply acts as a holder for the stirrups. The brick ledge stirrups can be created either in the field, or be provided pre-bent to the site by the reinforcing supplier. NUDURA can provide details showing the bend locations along with the required dimensions for the various wall thicknesses. Contact the local distributor for copies of these brick ledge hook details.

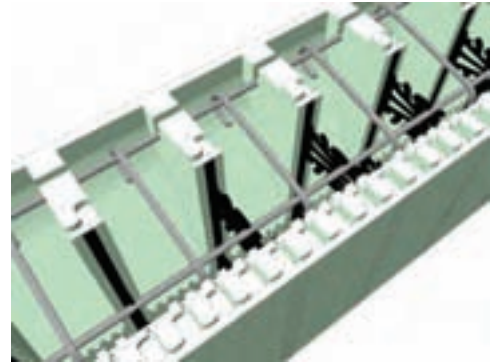

FIGURE 6.49

GABLE ENDS

If the structure is using parts or all of the roof section as habitable living area, and these areas include gable ends, it is beneficial and effective to use the NUDURA® Integrated Building Technology Wall System for these parts. One of the simplest methods for creating a gable wall is to use NUDURA's 8' (2.44m) panels and insert webs to build the gables. Simply cut the panels to the desired slope of the gable, insert the webs, and cut any of the webs extending above the cut portion of the gable. Remember that the cut off portion of the panel is not waste and can be re-cut to form the opposing slope of the gable end. This results in little or no waste, depending upon the pitch of the roof. The cut edges of the gable will require additional support during concrete placement to prevent flaring out of the panels due to the cutting of the webs. Simply taking 1"x4" (19mm x 89mm) or similar material and screwing into the fastening strips of the panels will ensure the gable ends maintain straightness during the concrete placement. The NUDURA alignment system then can be installed to support these areas as per section 6.6.



FIGURE 6.50

Should the gable wall have a window opening located within it, the buck options, temporary bracing, and anchorage into the concrete will be installed as per instructions given in section 6.5. The lintel reinforcement is also installed as per this section, and the reinforcing steel requirements are as per Appendix E of this manual.

When placing concrete into the gable ends, it will be necessary to reduce the overall slump from the typical 6" (152mm) to about a 4" (102mm) slump. Also, depending upon the gable end slope, it might be necessary to reduce the pour lift heights from 4' (1.22m) to 2' (0.61m). Consolidation of each lift is critical to ensure voids do not occur within these areas. Proper consolidation techniques are discussed in section 6.10. Regardless of slope of the gable, with the reduced slump there is no fear of the concrete slipping out of position as the regularly spaced web network inside the forms serves to prevent this from happening.

Once the gables are completely filled with concrete, remember to screed the top of the walls flat, install the necessary anchors as specified, and adjust the walls to obtain straightness.

INSTALLATION PROCEDURES

PILASTERS

Pilasters can be created, using a number of different methods, from products already discussed in this manual. Here are some of the available options:

1. Pilasters constructed using T Form units and end caps
2. Pilasters constructed using the 4 Way Web Connector and NUDURA® panels
3. Pilasters constructed from conventional form ply and attach this to the NUDURA form units

All of these methods will require additional form support, as portions of the wall will be compromised due to cutting of the webs.

T Form Unit Method: If the building requires a pilaster of 12" (305mm) or less, construction of the pilasters using NUDURA T Form units is a quick and easy option that will allow the contractor/installer the opportunity to build them fully using the NUDURA® Technology. The T Forms will allow the contractor/installer to build the pilaster as necessary to meet the specifications due to the fact that the forms come unassembled to the site. This helps in the placement of the steel reinforcement necessary for the pilaster to be placed where needed. It also helps the contractor/installer build this area similar to conventional forming by erecting the panels for 1 side of the pilaster, adding in the necessary reinforcement and then closing up the opposite side.

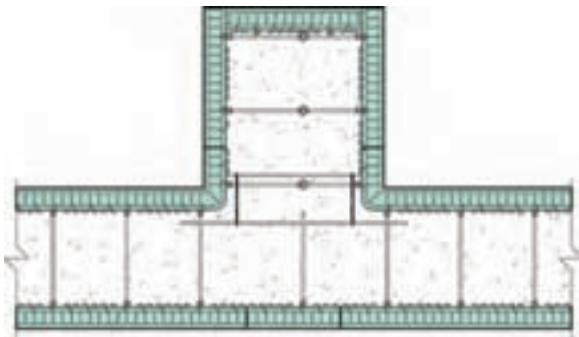

FIGURE 6.53

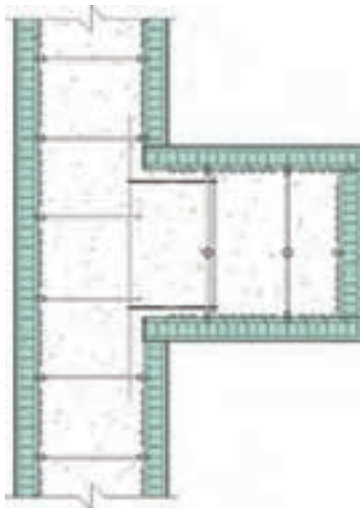

FIGURE 6.54

Panel and 4 Way Web Connector Method: Pilasters can also be created from NUDURA's panels, insert webs, and 4 way web connectors. These can be created by simply cutting the panels to match the required dimensions of the pilaster specified. A combination of insert webs to create the pilaster width and depth will require the use of NUDURA's 4 way web connector. For example; if the plans specify a 16" (406mm) x 16" (406mm) pilaster, a combination of 4- 8" (203mm) insert webs along with 1- 4 way web connector is required. Additional support will be required in the corners to prevent concrete from creating a problem during placement. NUDURA's low expansion spray foam will connect the panels together, giving the necessary bond strength to resist concrete.

Conventional Plywood Forming: The final option is to build the walls using the standard forms, cutting away the foam, and create a pilaster using regular plywood forming. This sometimes maybe preferred due to the amount of reinforcing steel needed for the pilaster to support the loads imposed upon it. Should this be the method, simply cut out the required amount of foam from the main wall. Do not forget to add additional support to the opposite side of the NUDURA® form to resist concrete pressure. Complete the pilaster as per normal techniques. Remember to tie wire the forming to the forms to ensure the pilaster does not move under concrete pressure.

6.10 CONCRETE SPECIFICATIONS AND PLACEMENT

The concrete mix design shall meet the engineer's specifications and conform to national and local standards, regulations or codes having jurisdiction. The main characteristics and specifications for a NUDURA® compatible concrete mix should be as follows:

- Portland cement: Type 10 (Normal)
- Designed compressive strength at 28 days: 3000 psi (20 MPa)
- Slump on site: 5" (125mm) to 6" (150mm)
- Water/cement ratio: Maximum 0.60
- Aggregate maximum size:
 - Wall Cavity of 4" (100mm) and 6" (150mm) nominal concrete thickness: 3/8" (10mm) to 1/2" (13mm) aggregate size
 - Wall Cavity of 8" (200mm), 10" (250mm) and 12" (300mm) nominal concrete thickness: 3/4" (19mm) aggregate size
- No air entrainment (usually 3% to 5% present naturally)
- Fresh concrete density: 4080 lb/yd³ ± (2400 kg/m³ ±)
- Setting time (dependent on temperatures): 3 – 7 hours
- Concrete design strength should be reached at 28 days



FIGURE 6.56

Check this specification with your local concrete supplier. Most concrete companies now feature design mixes formulated with mid-range water reducers that are specifically designed to work in Insulated Concrete Forms systems. These mixes give better flow-ability of the concrete with reduced water content and more cohesiveness that assures no segregation of aggregate during placement.

The NUDURA® form units made of EPS (expanded polystyrene) will enhance the curing of the concrete as follows by:

- Providing consistent curing environment for the concrete
- Giving excellent thermal protection in the cold weather and extreme heat
- Minimizing surface shrinkage which is the cause of cracking in concrete walls
- Controlling moisture loss inside the concrete while curing, which is the major cause of cracking
- Preventing moisture loss due to air/wind exposure

Typically, concrete design strength characteristics and number of days at which the design strength will be achieved are as follows:

- 3 days - the concrete achieves approximately 40% of its design strength
- 7 days - the concrete achieves approximately 60% of its design strength
- 28 days - concrete compressive design strength should be reached

The placement of concrete in the NUDURA® forms shall be in accordance with the plans and specifications, and must comply with local standards, regulations or codes having jurisdiction. Various methods of placement can be used depending on the accessibility to the site and the characteristics of the project. Other variables such as temperature, mix design, and reinforcing pattern in the wall may influence the builder's decisions as to the technique selected for the concrete placement. Concrete can be placed using the following methods:

- Concrete boom pump
- Concrete pump
- Crane and bucket
- Conveyer belt on or off the truck
- Directly off the truck by chute

INSTALLATION PROCEDURES

The concrete boom pump is the preferred method for above grade construction when available. When using a boom pump it is important to have a reducer (diameter 4" (102mm) maximum) followed by a double 90° bend to reduce the velocity of the concrete entering the wall. Some pumps are also equipped with a flap gate at the end of the double 90°. The flap gate is very useful in keeping the site clean, especially when working on slab or floor surfaces.

The contractor and crew should familiarize themselves with the proper technique and use of the vibration equipment supplied for the job before concrete placement begins. A recommended practice for a standard whip vibrator is to insert the vibrator full depth of the concrete lift at 2'-0" (600mm) intervals and withdrawing the vibrator slowly at a rate of about 1 foot (300mm) per second after each insertion.

Though following the practices recommended in this installation manual will assure maximum efficiency and safety during the pour, it's a good idea to ensure that preparations are made for handling a form blow-out, should anyone miss cross checking for adequate form support etc. The contractor should ensure that prior to concrete placement, one or more kits are prepared to have at the ready should such an occurrence arise. A blow out kit can consist of such simple materials as a 2'-0" x 2'-0" (600mm x 600mm) square of ½" plywood or multiple 2'-0" (600mm) long grade stakes and No. 10 x 2 1/2" (63.5mm) wood screws with a screw gun. Having these ready will save valuable time should a blow-out occur.



FIGURE 6.48

PRE-PLACEMENT CONCRETE CHECKLIST

- Is wall built according to drawing?
- Has all additional support been installed?
- Is rebar installed per plans or as specified in the correct location?
- Is lintel rebar installed correctly?
- Is NUDURA® alignment system installed correctly?
- Have all openings been installed and in correct location?
- Do you have correct size of rough openings?
- Has proper anchorage for buck material been used?
- Construction joint reinforcement or protection for protruding rebar?
- Have all service penetration sleeves been installed?
- Have all T Form units been braced?
- Have all beam pocket preps. been installed and in correct location?
- Have all string lines been installed around perimeter of building?
- Have walls been straightened?
- Has all interlock been protected?
- Is there adequate support on gable ended walls?
- If in winter construction, has form cavity been protected against snow or ice build-up on the night previous to the pour?
- If no protection had been provided, have measures been taken to remove all snow and ice from the forms?
- Are roof or floor connection anchors on site?
- Do you have a tool for consolidation? (Concrete vibrator)
- Are there back up materials in case of blowout? (i.e. blow-out kits and screw gun available)
- Is the concrete order as per code, or as specified?
- Has the quantity of concrete been properly calculated and checked against the build?
- Has the timing of trucks been properly coordinated with the plan for the pour and relayed to the concrete company?
- Is there enough room for concrete pump or trucks to maneuver on site?
- Has operator been made aware of all trees, roof overhangs and power wires?
- If pouring with a pump are there reducers along with a double 90° elbow?
- If pouring by other means is there enough room to maneuver around site?

TOOLS FOR CONCRETE PLACEMENT

- Magnesium trowels
- Homemade trowel to recess plate
- Concrete vibrator
- Laser level
- Hand level
- Ladders
- Wheelbarrows
- Normal hand tools
- Cordless drill and screws
- 4' (1.22m) and 8' (2.44m) straight edge
- Material for supplementary bracing and straightening
- Hand shovel

As outlined previously under Pre-Construction Planning in Section 2.6 and under Site Planning (Section 4.0) of this manual, after completion of the pre-placement checklist, and cross check of the required tools has been completed, and once the pump truck is set in initial position and at ready for the arrival of the first concrete truck, the crew should be ready to begin work to place the concrete. The operations outlined here are for a typical four man work crew for a typical residential pour. Please note that operations can vary widely from what is depicted here depending upon job complexity and size.

Slump of the concrete should be checked by the crew lead before placement begins to assure it is being pumped at the specified mix. Accurate records of the concrete delivery tickets should also be kept during concrete placement for later reference in the event that concrete testing is required.

Ideally, the lead hand should be working the hose alongside the pump operator on the catwalk platform. A laborer should follow immediately behind the lead hand with the vibrator, consolidating as the lift is placed. Communication between pump operator and the crew lead operator at the hose end is crucial. If the pump operator does not have remote equipment, radio, or clear hand communications between these operators will be essential for a successful pour.

Additional laborers should be on the ground assisting in mechanical vibration (external or internal) especially at window openings, and watching carefully for wall movement or potential situations that may arise due to concrete pressures filling various areas of the formwork. These crew laborers should also be ready with embeds or accessories and tools as needs may arise during the pour. The crew on the ground should always be cautious of the boom position and be ready to react in the event of any emergency that should arise with the pump equipment.

As per ACI 304 and CAN/CSA A23.1, (in North America) concrete placement rate should not exceed 4' (1.22m) of lift per hour. When placing concrete the contractor should avoid stopping a pour against a buck or in a corner. A pour should always be terminated at the center of the longest wall when possible.

Consolidated concrete will be dense, homogenous, and free of cold joints, voids, and honeycombing. The concrete shall be well bonded to all reinforcing steel, anchors, and embedded parts, such as bearing plates. Concrete can be consolidated by means of hand-tamping, rodding, or external or internal mechanical vibration. Of these, internal mechanical concrete vibration is the most effective method to use. Consolidation of the concrete should always start at the base of the wall and continue upward as each concrete lift is placed. The completed lift should be consolidated before the next lift is deposited.

When consolidating subsequent lifts, the consolidating tool must completely penetrate the lift and extend into the upper portion of the previously placed lift, to ensure proper mixing of the concrete at the interface between lifts. A 3/4" (19mm) to 1" (25mm) concrete vibrator is the maximum size recommended for consolidating concrete in a NUDURA® wall. Be sure that the shaft length of the vibrator is long enough to reach the bottom of the wall height being constructed.

INSTALLATION PROCEDURES

As the concrete placement operations near the top of the wall pour, one of the ground laborers should move to the scaffold platform to assist with embed placements, beam pocket screeding and wall leveling. A laborer should remain on the ground to assist the crew lead with the alignment system checks. An initial alignment should be made to plumb and to assure visual straightness. Once the crew has completed leveling, screeding, and anchor bolt and embed placement, the crew lead should complete fine adjustment with a single laborer on the ground to ensure that minimum movement of the alignment system is made during the final plumb and straightness checks of the wall installation.

Once the work is complete, the crew finishes off with final clean-up of the site and the equipment and completing the post-placement checklist.

POST PLACEMENT CONCRETE CHECKLIST

- Have the walls been preliminarily straightened to plumb?
- Are openings plumb?
- Have all walls been properly consolidated?
- Has the top of wall been screed level?
- Have all beam pockets been screed to level where accessible?
- Have all anchor bolts and embedment has been installed and concrete consolidated at these inserts?
- If continuing up wall, is all cold joint reinforcement in place with proper lap splice and top of concrete left rough?
- Once all cross checks completed above, has final fine adjustment of all walls been completed using installed string lines, tape measure and laser level?
- Have all tools been cleaned and put away?
- Cold weather pouring – has top of wall been protected from freezing?
- Has alignment system been cleaned of all excess concrete?